

EBOX-336x Series

User's Guide



Copyright

The information in this manual is subject to change without notice for continuous improvement in the product. All rights are reserved. The manufacturer assumes no responsibility for any inaccuracies that may contain in this document, and makes no commitment to update or to keep current information contain in this manual.

No part of this manual may be reproduced, copied, translated or transmitted, in whole or in part, in any form or by any means without the prior written permission of the DMP Electronics Inc.

©Copyright 2019 DMP Electronics Inc.

Trademarks Acknowledgment

DMP[®] is the registered trademarks of DMP Electronics Inc.

Other brand names, product names or trade names appearing in this document are the properties and registered trademarks of their respective owners. All names mentioned herewith are served for identification purpose only.

Safety Information

WARNING

- Do not expose EBOX to rain or moisture, in order to prevent shock and fire hazard.
- Never install EBOX in wet locations.
- Do not open cabinet to avoid electrical shock. Refer to the nearest dealer for qualified personnel servicing.
- Never touch un-insulated terminals or wire unless power adaptor and display monitor are disconnected.
- Locate EBOX as close as possible to the socket outline for easy access and to avoid force caused by entangling of your arms with surrounding cables from the EBOX.
- When using EBOX, avoid using or installing the modem to the serial port during a storm or a lightning.
- Do not use the modem or a telephone to report a gas leak in the vicinity of the leak.
- USB connectors are supplied with Limited Power Sources.

**DO NOT ATTEMPT TO OPEN OR TO DISASSEMBLE THE CHASSIS (ENCASING)
OF THIS PRODUCT. PLEASE CONTACT YOUR NEAREST DEALER FOR
SERVICING FROM QUALIFIED TECHNICIAN.**

Regulatory

FCC Class A Note

This equipment has been tested and found to comply with the limits for a Class A digital device, pursuant to Part 15 of the FCC Rules. These limits are designed to provide reasonable protection against harmful interference when the equipment is operated in a commercial environment. This equipment generates, uses and can radiate radio frequency energy and, if not installed and used in accordance with the instruction manual, may cause harmful interference in which case the user will be required to correct the interference at his own expense. Testing was done with shielded cables. Therefore, in order to comply with the FCC regulations, you must use shielded cables with your installation.

WARNING

This product complies with EN55022 class A. In a domestic environment this product may cause radio interference in which case the user may be required to take adequate measures.

Changes or modifications to this unit not expressly approved by the party responsible for compliance could void the user's authority to operate the equipment.

This device complies with Part 15 of the FCC rules. Operation is subject to the following two conditions: (1) this device may not cause harmful interference, and (2) this device must accept any interference received, including interference that may cause undesired operation.

This digital apparatus does not exceed the Class A limits for radio noise emissions from digital apparatus as set out in the interference - causing equipment standard entitled "Digital Apparatus", ICES-003 of the Department of Communications.

Manufacturer's Declaration of Conformity

This equipment has been tested and found to comply with the requirements of European Community Council Directives 89/336/EEC & 73/23/EEC relating to electromagnetic compatibility and product safety respectively.

Attention

This product has been designed and certified to comply with certain regulatory requirements pertaining to Information Technology Equipment. This product has not been designed for use as a medical device. Without limitation of the foregoing, this product is not intended and has not been certified for use in a hospital or clinical environment to diagnose, treat, or monitor patients under medical supervision, and is not intended and has not been certified to make physical or electrical contact with patients, nor to transfer energy to or from patients and/or to detect such energy transfer to or from patients.

Purchase Agreement

Purpose:

In accordance to the general commercial conduct of Trust and Fair Trade, herewith below is the agreement for the protection for both parties, DMP and Users in pursuant of trading.

Product Description:

With this product, herewith also known as EBOX-336x Series, which is a simplified and economical design of an embedded device for Special Purpose Personal Computing. The basic specifications of this product is comprised of the x86 technology design, and with onboard 1GB/ 2GB DDR3 System memory, VGA or HDMI display, USB, COM ports, and LAN Interfaces.

Distribution Convention:

1. This Product includes a PC and a power supply unit. Upon receiving this product, please refer to user manual to check for the contents and appearance of this product; contact the nearest dealer or DMP office for any defective or missing parts immediately. The supplier will not be responsible for any reported discrepancy there after the expiration period of 3-days from the received date.
2. In consideration of transportation and the cost of storage, the supplier provides to the distributors a warranty of 12 months. This warranty covers the failure caused by hardware breakdown (excluding hard drives), but does not cover the act of misuse and mishandling.
3. The supplier will not accept unknown post, therefore if you wish to repair or to return your goods – kindly please contact your nearest dealer to make your declaration, and at the same time, apply for an RMA number (RMA stands for Return Merchandise Authorization – please ask for RMA form and fill-up for authorization).
4. The freight for return goods for repair will follow the International customary practice and convention: Both parties is to pay for freight of one shipment each. The shipper is required to prepay the freight from the place of origin (This means that the returnee (user) covers the freight for return goods, while the Supplier covers the freight for goods after the repair).
5. Obsolete warranty is referred to as: (1) Expiration of warranty or (2) Damage due to misuse within warranty. The Supplier will be taken into consideration of the circumstances, to provide repair service with charges expense for obsolete warranty. This expense includes the cost of material and the cost of labor.

Note: If there is other particular issue, not listed in the above conditions, both parties agreed to follow the General Law of Commerce with fair and reasonable discussion in handling and resolving the argument.

Contents

Chapter 1

- 07 Unpacking EBOX Mini PC

Chapter 2

- 10 EBOX-336x Series Overview
- 12 System Specifications
- 14 SD card recommendation

Chapter 3

- 16 BIOS Reconfiguring
- 17 mPCIe signal setting
- 18 Boot setting
- 19 PXE Diskless Boot setting
- 22 Drivers Installation
- 25 Additional information
- 25 Disable TRIM function
- 26 Screen rotation
- 27 Turn off the display function setting
- 28 HDMI 1080p video playback
- 29 CANbus information
- 30 Linux Installation guide

Chapter 4

- 37 Onboard Connectors Summary
- 38 Pin Assignments

Chapter 5

- 45 Taking Care of EBOX
- 46 Troubleshooting

Chapter 6

- 49 Terms and Condition
- 49 Warranty
- 49 Service and Support
- 49 Return Merchandise Authorization (RMA) Policy
- 49 Shipping Policy

Chapter 1

Unpacking EBOX Mini PC

Component List:

Item No.	Description	Quantity
1	EBOX-336x Series Mini PC	x1
2	22.5W Power Adaptor, Vin: 100~240V AC 50~60Hz	x1
3	Power plug (available US, UK, EU, AU types)	x1
4	VESA screw	x4

Note: The accessories are subject to change without immediate notice.

Check before Use



Preface

EBOX-336x Series Mini PC

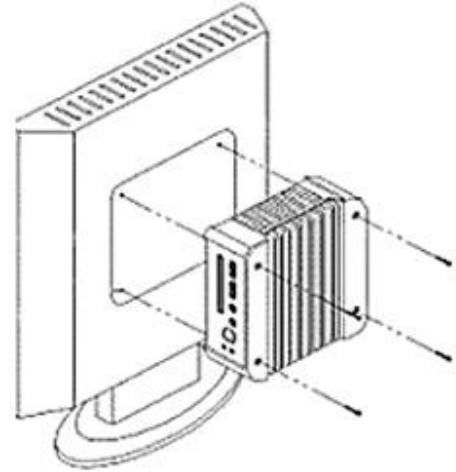

EBOX-336x Series is a revolutionary device which is especially designed for limited physical space and temperature concerns. No matter you are in a jammed office, a crowded place, or public transportation, EBOX-336x can be easily integrated with a VESA monitor to access at any time.

EBOX-336x can be attached to any VESA mounting fixture; allowing it to be securely mounted onto desks, walls, or buildings, and thereby optimizes your work area. It can also be attached directly to any size LCD for a mobile system for the use at trade shows, presentations, promotions, etc. With FANLESS design, the EBOX-336x Series is ideal to be used in the environment where temperature demand is critical.

The VESA® FDMI™ Standard defines mounting interfaces, hole patterns and associated cable/ power supply locations for LCD monitors, plasma displays and other flat panel devices. The EBOX-336x Series is designed to fit this standard to make monitor attachment quickly and easily.



Chapter 2

EBOX-336x Overview



Front Panel

A: Power LED

LED lights up when the system is turned on

B: SD Card LED

Green flashing LED indicates SD Card activity

C: Line Out

Line out is default in EBOX-336x Series, change to Mic in is available as an option

D: USB 2.0 port

Connection for external USB devices

E: SD Card slot

For storage SD Card, the system is bootable from SD Card

F: COM port

COM3 is optional for RS-232/485 or 8-bit GPIO port



G: COM port

COM4 is optional for RS-232/485, 8-bit GPIO or CANbus port

H: CF card Slot

The system is bootable from CF Card

H: Mic in

For Microphone input



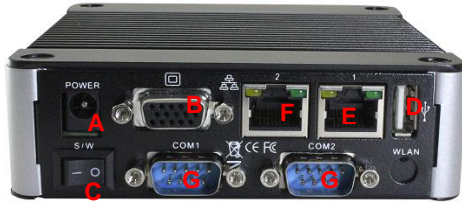

Back Panel

A: Power Jack

Volt: DC +8V ~ +24V

B: VGA port

Support VGA display

C: Power switch

Support HDMI display

D: USB 2.0 port

Connection for external USB devices

E: RJ-45 LAN Jack

RDC R6040 10/100 Mbps LAN

F: RJ-45 LAN Jack

Realtek 8111F GBE 1 Gbps LAN

G: COM port

Optional for RS-232, 485, 422 or GPIO



H: HDMI Output port

Support HDMI display

I: COM port

Optional for RS-232 port



J: Printer port

Parallel port for connecting peripheral



EBOX-336x Series

System Specifications

Processor	DM&P 32-bit x86 Dual Core Vortex86DX3 (1GHz) SoC
BIOS	AMI BIOS
Memory	Onboard 1GB/ 2GB DDR3-1600MHz
Storage	SATA/ mPCIe SATA Gen1 x1 , 7-pin internal/ Standard Mini PCIe x1
	SD SD Slot x1 (SD, SDHC)/ (optional Internal SD slot)
Display	VGA Integrated Graphics Chip/ D-Sub 15-pin (max. 1920×1080 pixels)
	HDMI HDMI V1.4 (max. 1920×1080 pixels)
USB	USB V2.0 x3 (Front x2, Rear x1)
HD Audio	Realtek ALC262VD Line-out (optional Mic-in)
Ethernet	RDC R6040 10/100 Mbps LAN x1 (RJ-45 connector, Built-in PXE diskless boot)
	Realtek 8111F GBE 1 Gbps LAN x1 or 2 (optional)
COM	DB9 RS-232/ 485/ 422/ 8-bit GPIO/ CANbus (optional TTL RS-232)
Power	DC +8V~+24V input
Dimension	115 x 115 x 35 mm
Mounting	VESA 100 x 100 mm
Auto Power On	Supported
Weight	510 g
Operating Temp.	0-60°C / -20-60°C
Certifications	CE, FCC, VCCI
OS Support	Windows 7, WES7, Windows XP, XPe, CE 6.0, Compact 7 and Linux OS

Connecting the Power Adaptor



A: DC power Jack

EBOX-336x Series use +15V@1.5 A power supply with switchable power plug for the power source

B: Power switch

For system power on/off

Note: Unit with Auto Power On function, system will boot up automatically after power restored

Connecting the Monitor



B: VGA Connection

Connecting VGA display via VGA cable



C: HDMI Connection

Connect HDMI display via HDMI cable

SD card recommendation

Class 10 SD card for EB-336x Series is highly recommended.

EB-336x Series support SD and SDHC only, it does not support SDXC.

Users may be able to use SDXC on EB-336x, however, SDXC will be recognized as SDHC and capacity support up to 32GB only.

Test environment:

Products: EB-336x Series

SD card: Kingston Canvas Select SDXC UHS-I 64GB Class 10

BIOS: AMI BIOS

OS: WES7 (Windows embedded standard 7)

Disk benchmark software: CrystalDiskMark 6.0.2

Test result:

	Seq Q32T1 Read	Seq Q32T1 Write
SD card Speed	21.34 MB/ s	15.39 MB/ s





Chapter 3

BIOS Reconfiguring

AMI BIOS is used in the EBOX-336x Series. To reconfigure the BIOS, press key repeatedly to enter BIOS setup main menu as below:

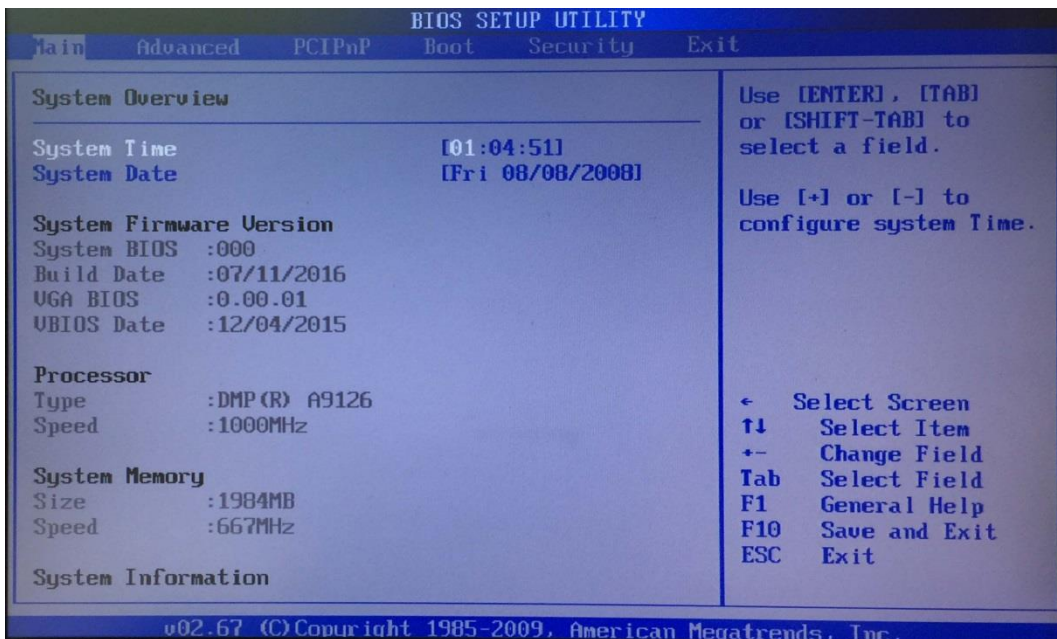

Use ← and → keys to select screen; ↑ and ↓ keys to scroll the selected item. Press <ESC> return to previous screen and press <F9> if you want to load factory default setting. Following guide concentrated only those settings that may need to change.

Primary IDE Pin Select setting:

1. Boot up EBOX unit and press to enter BIOS menu.
2. Move to **Advanced** "Primary IDE Pin Select":
 - ➔ Parallel IDE = use 2.5" SATA HDD, SATA DOM or CF card as main storage.
 - ➔ SD Card = use SD card as main storage.
3. Press <F10> to save the setting and exit.

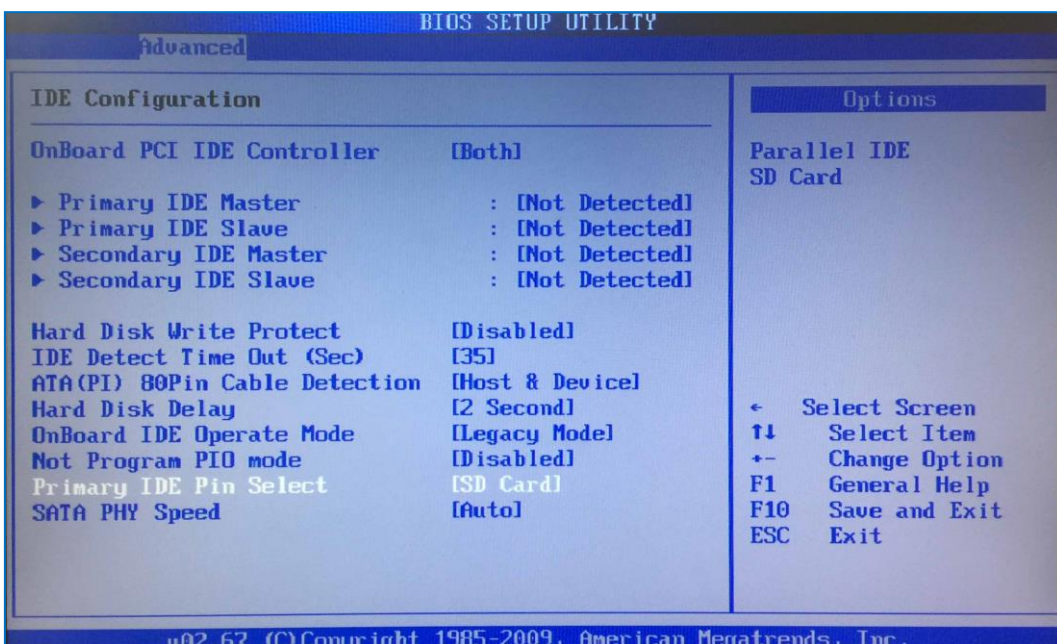

mPCIe signal setting:

EBOX-336x with mPCIe socket support both USB and COM port signals. And EBOX-336x mPCIe Series COM port signal support function defaulted as Disabled, user can use mPCIe via USB signal without setting.

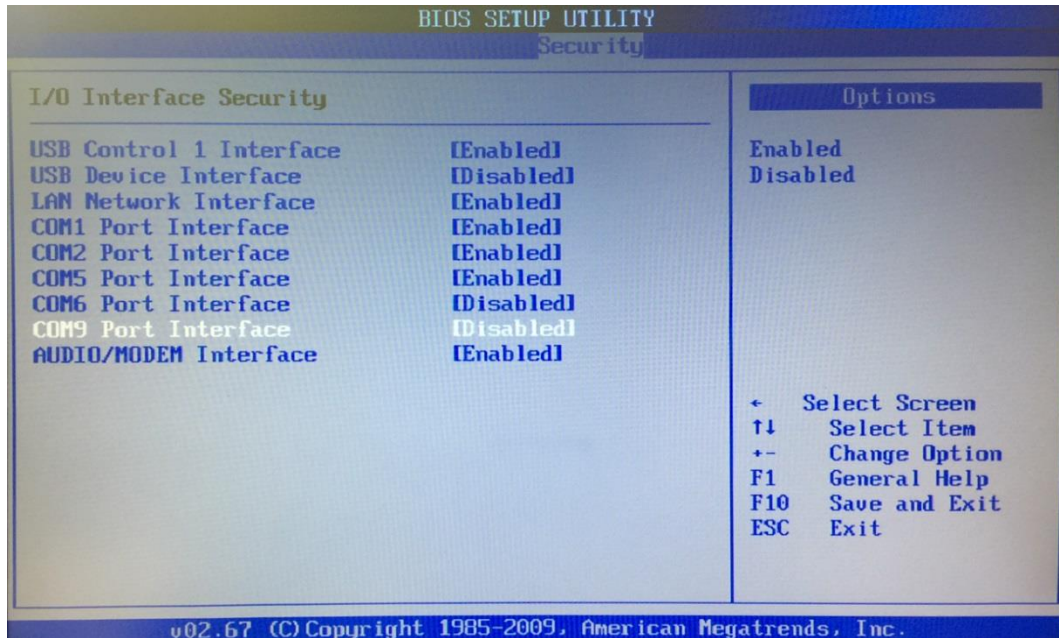

For user want to use mPCIe via COM port signal, set BIOS COM9 Port Interface enabled as below:
Move to **Security** → I/O Interface Security and set BIOS COM9 Port Interface as enabled. Press <F10> to save the setting and exit.

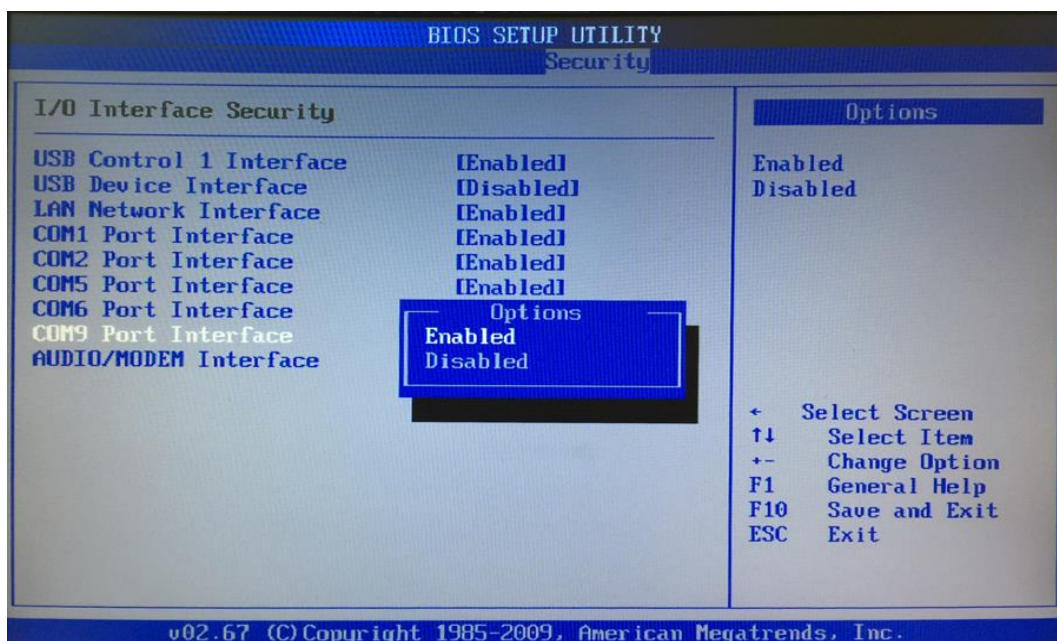

Boot setting:

1. Boot up EBOX unit and press to get enter BIOS menu.
2. Move to **Boot** "Boot Settings Configuration" and press Enter

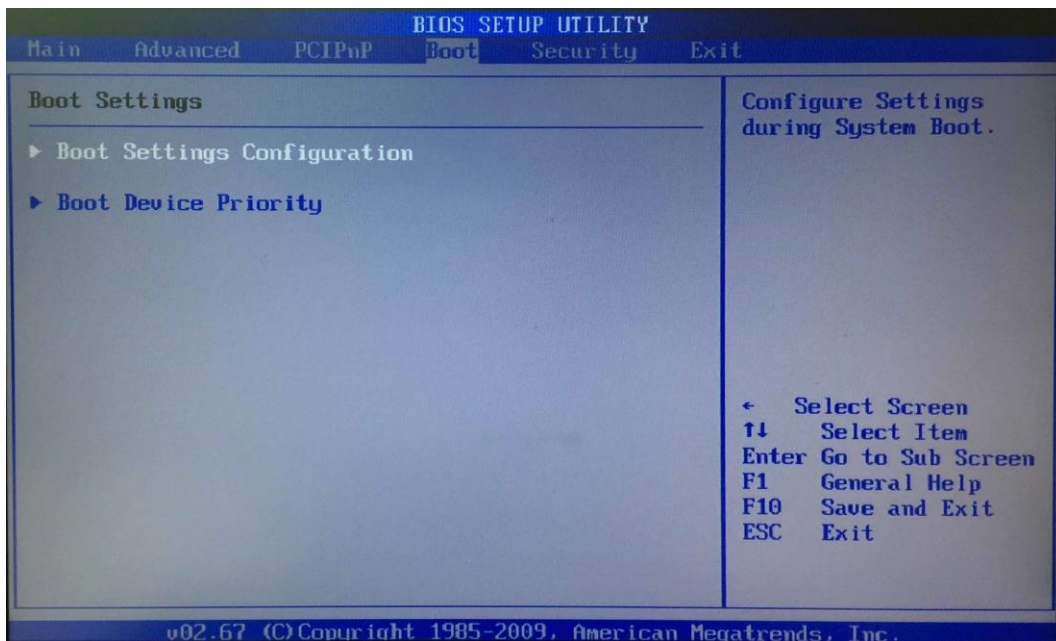

3. Set your main storage as 1st boot.

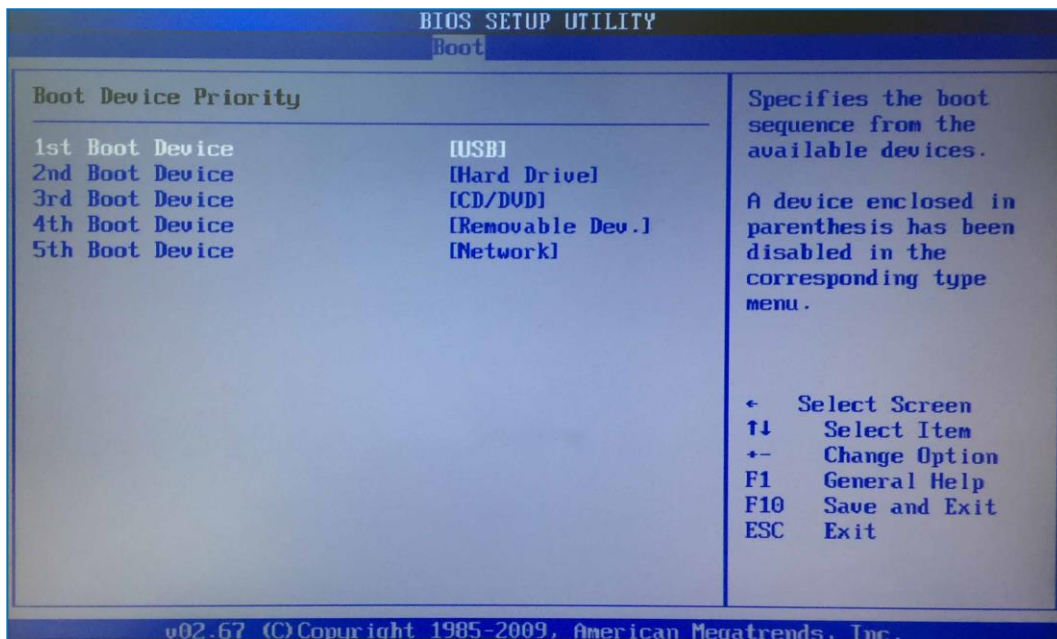

4. Press <F10> to save the setting and exit.

PXE Diskless boot setting:

1. Boot up EBOX unit and press to enter BIOS menu.
2. Move to **Boot** then select "Boot Settings Configuration" and press ENTER.

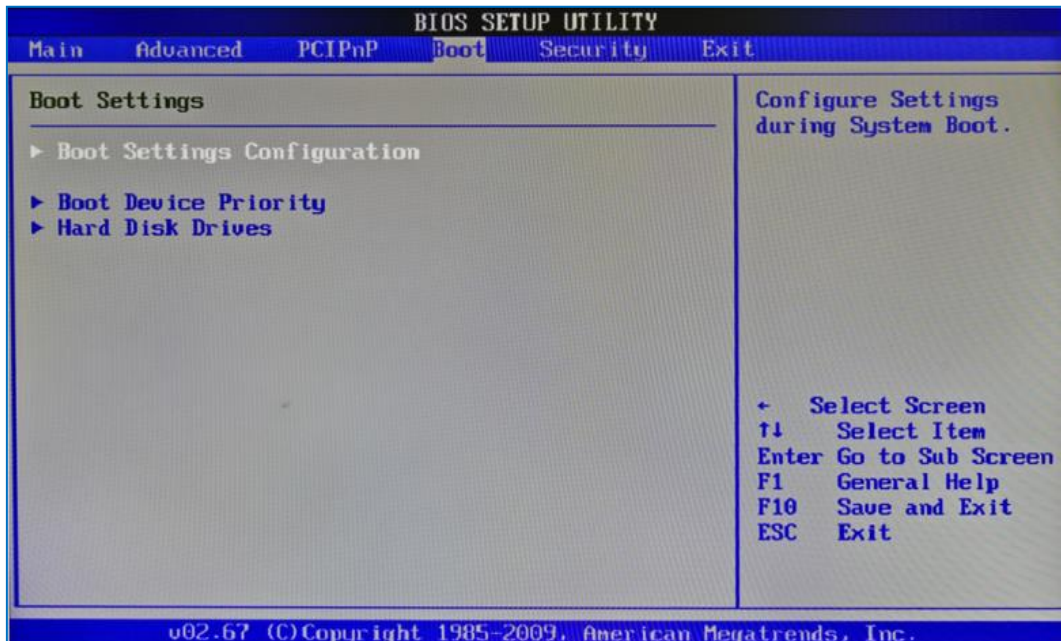

3. Move to "Boot From LAN" and choose "Used INT 19h" then press "F10" to save the setting and exit.

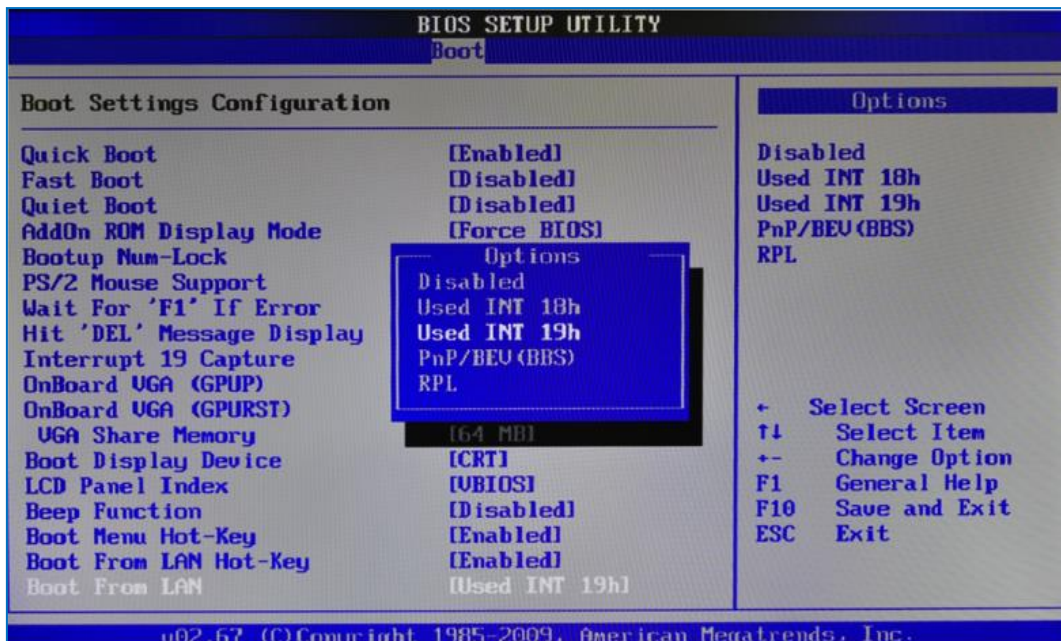

PXE Diskless boot additional setting:

EBOX-336x model with three or four COM ports required additional BIOS setting for PXE diskless boot. Users have to set COM5 and COM6 interface security “Disable” temporary in order to release IRQ resource for PXE diskless boot function.

1. Boot up EBOX unit and press to enter BIOS menu.
2. Move to **Security** then select “I/O Interface Security” and press ENTER.

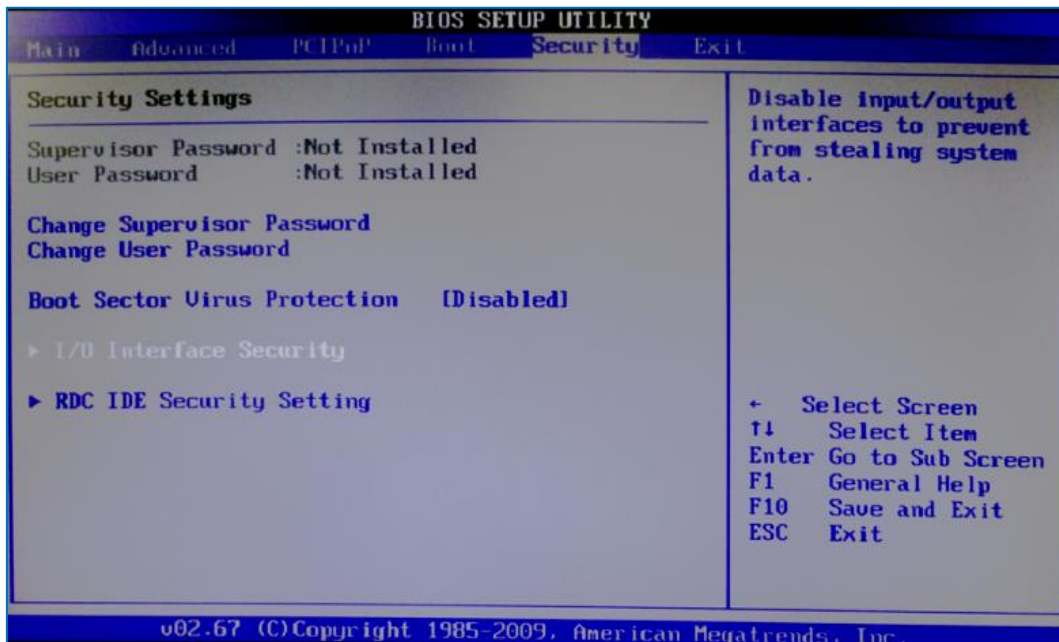

4. Disable “COM5 port” and “COM6 port” interface then press “F10” to save setting and exit.

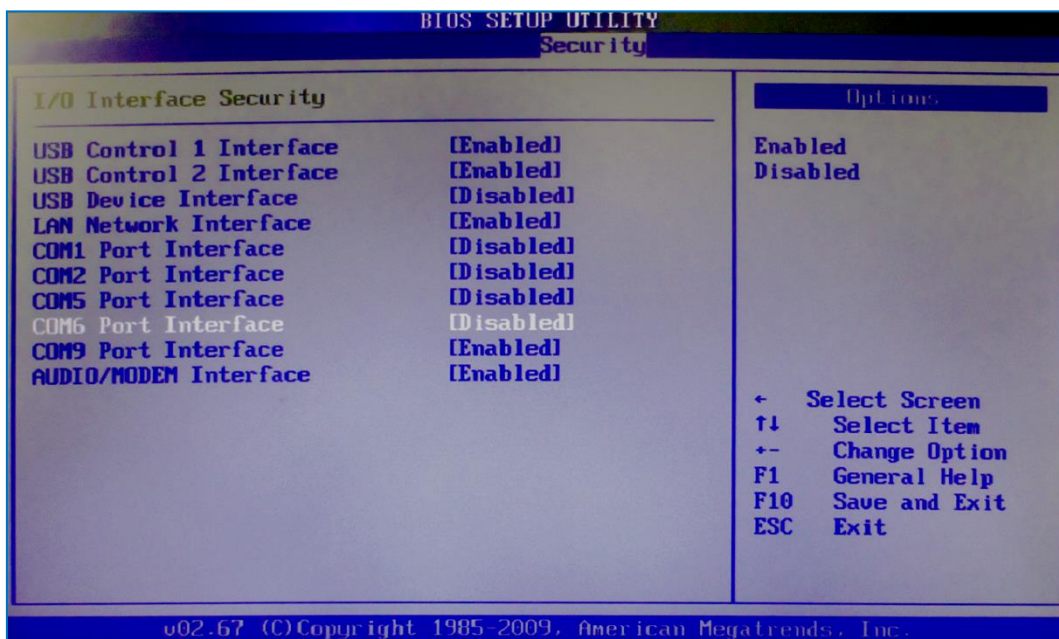

To resume the default setting:

1. Select "Security" then move to "I/O Interface Security" and press ENTER.
Enable "COM5 port" and "COM6 port" interface then press "F10" to save setting and exit.

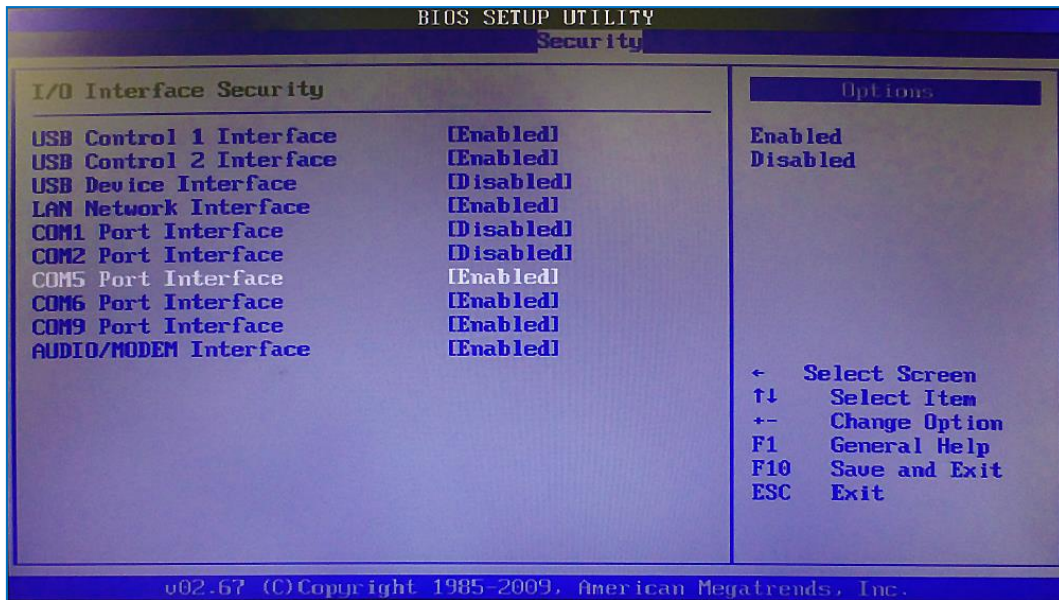

2. Or move to EXIT and select "Load Optimal Defaults" then press "F10" to save the setting.

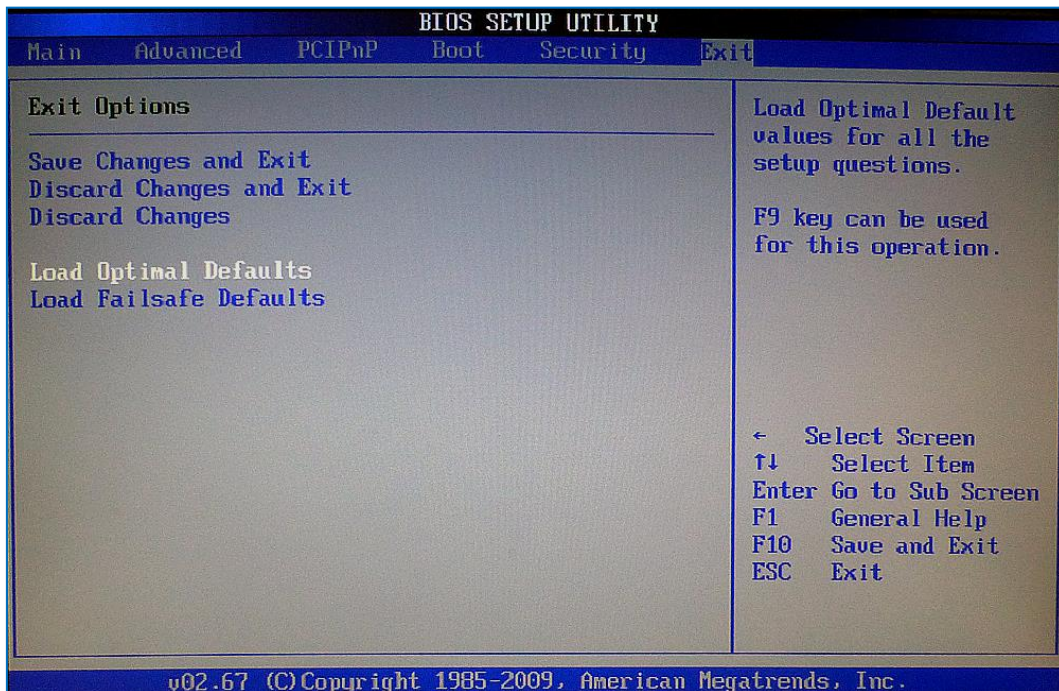

Drivers Installation guide

Under the Windows series OS, the following drivers need to be installed manually.

1. VGA driver
2. Ethernet driver
3. Wireless LAN Dongle driver (Optional)
4. Audio driver (for windows XP only)

Note:

1. Please download EBOX-336x Series drivers from EBOX website.
2. For Windows 7 or WES7 OS, install the XMPlay for audio player, download [here](#).

VGA driver:

Unzip downloaded file and double click to execute .exe file then “Next” as below to install:

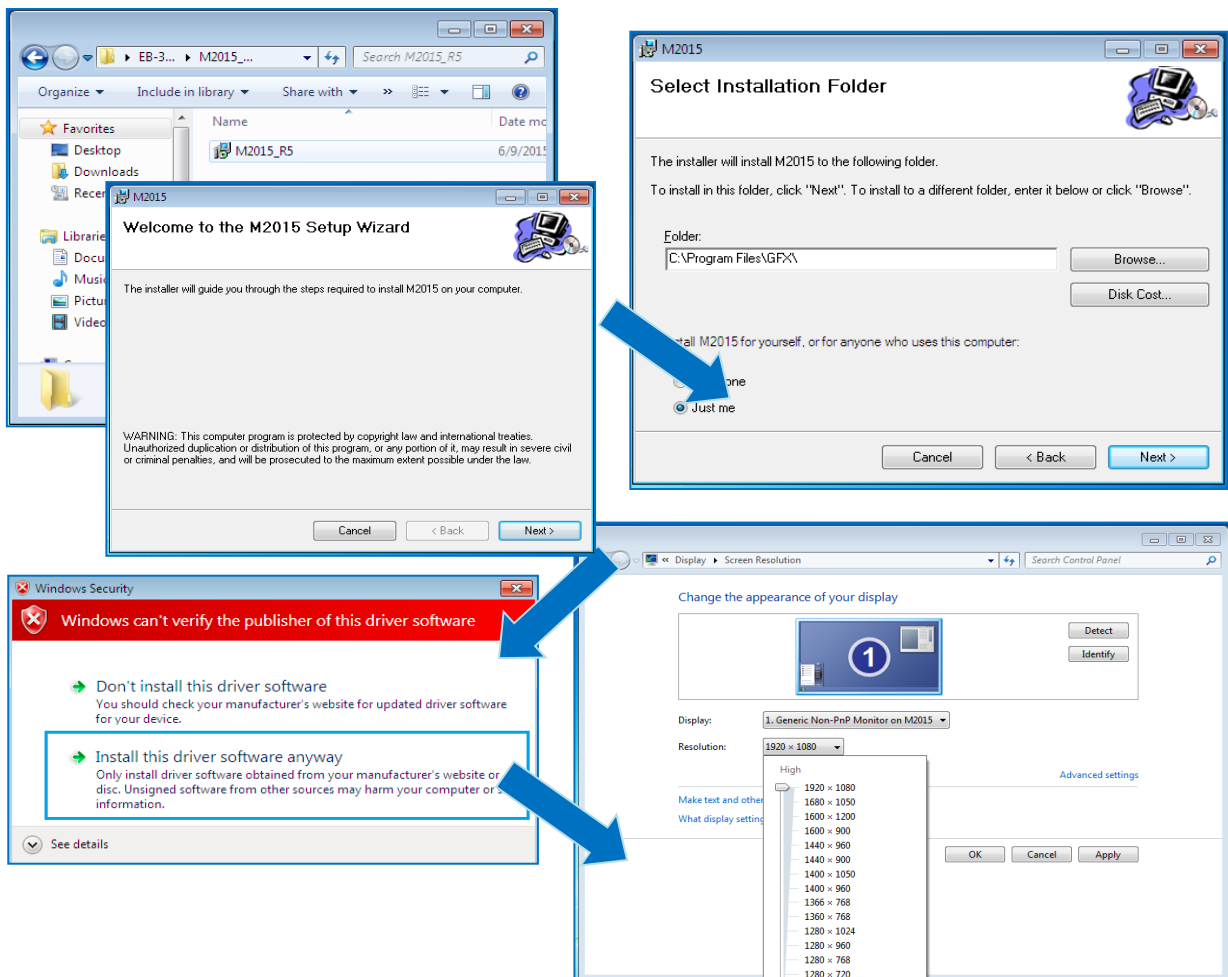

After VGA driver installation completed, you will have to restart the computer. Then you will be able to select the resolution up to 1920 x 1080 pixels.

Ethernet driver:

1. Download corresponding Ethernet drivers from EBOX website and unzip.
2. Find the yellow question mark of Ethernet in the Device Manager under the control panel/ system.
3. Select "Update Driver Software" and choose the unzipped driver folder path, then click "Install this driver software anyway" when Windows Security popped out.
4. After installation completed, the Device Manager will update and show the correct device.

Note:

1. For dual LAN version, the 1st question mark required 1G LAN driver installation.
2. For EBOX-336x-L3U4C1, the 1st and 2nd question marks required 1G LAN driver installation.

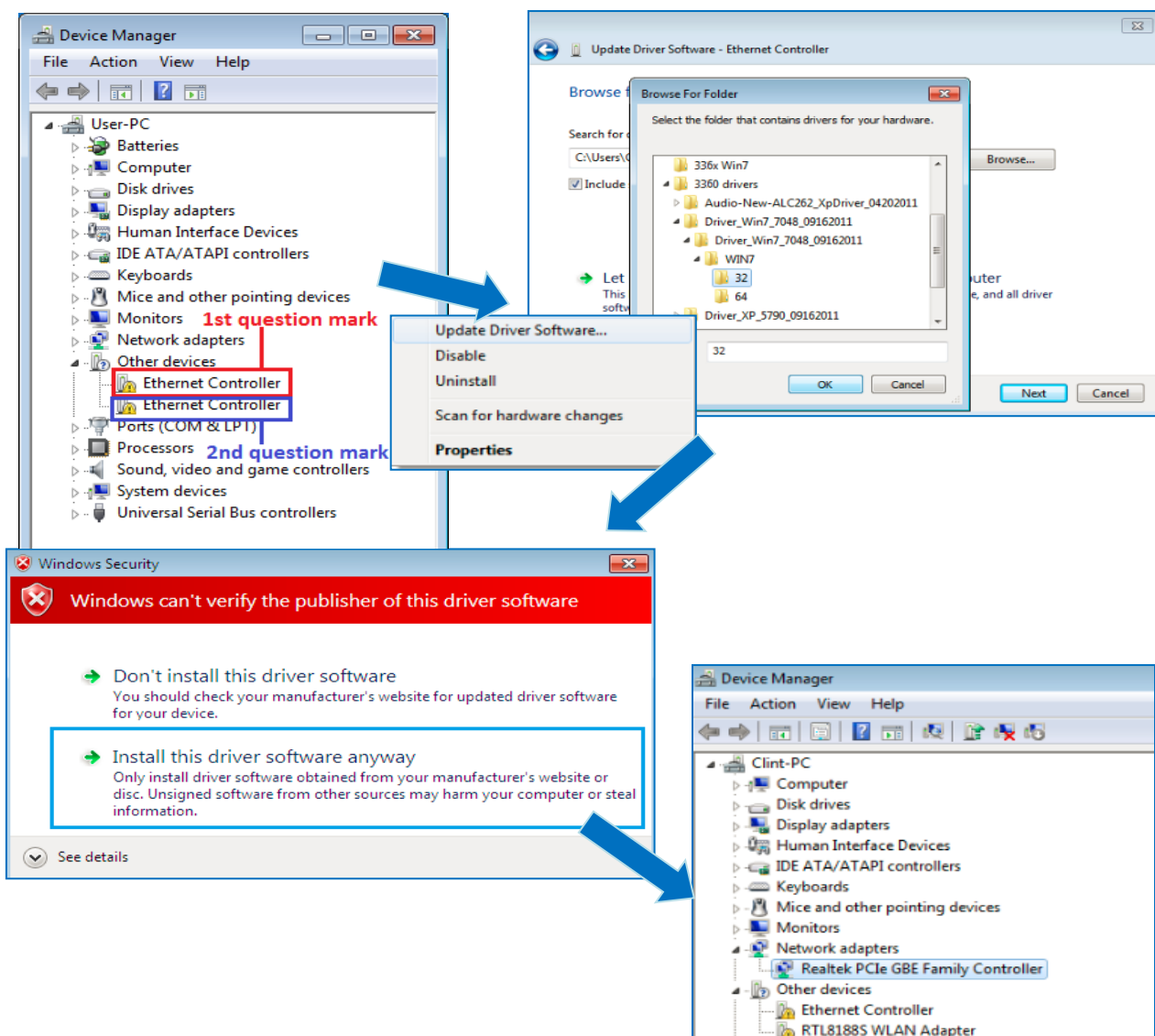

Audio driver:

Unzip the downloaded file and double click to execute .exe file, then “Next” as below to install. After the installation completed, the Device Manager will update and show the correct device.

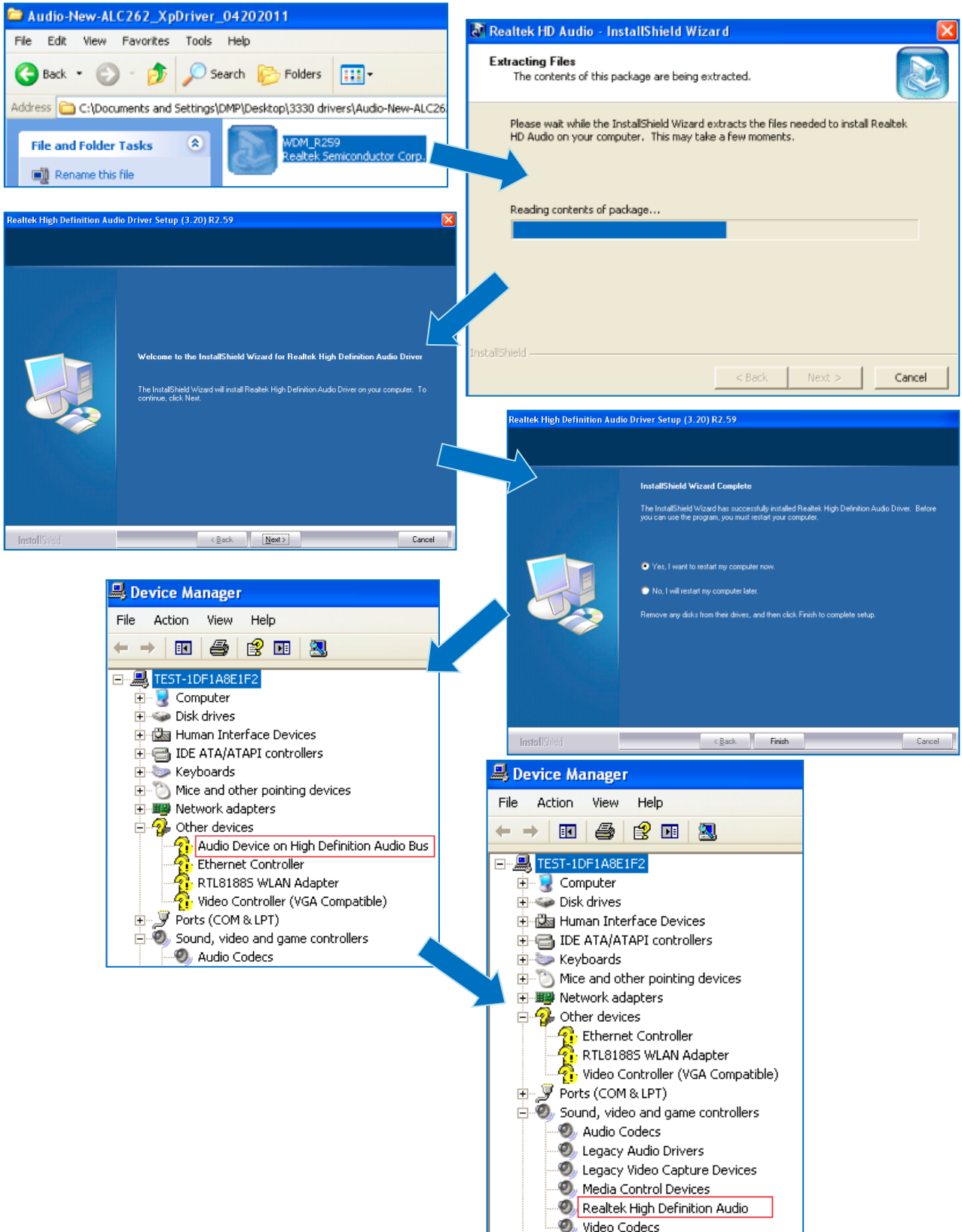

Additional information

Disable TRIM function:

TRIM function sets enable as default in Windows 7 and WES7 OS. EBOX-336x Series does not support storages with TRIM function (SSD/ Disk on Module). User has to disable TRIM function manually by following steps:

1. Open command prompt as Administrator.

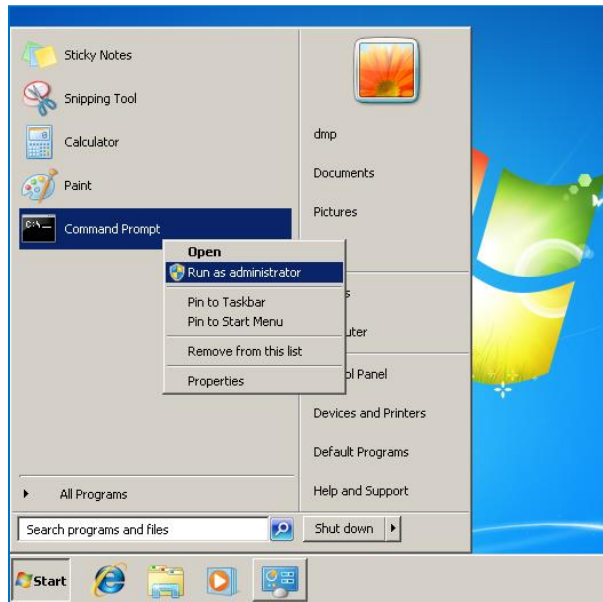

2. Execute **fsutil behavior query disabledeletenotify** to check TRIM status.

```
Administrator: Command Prompt
Microsoft Windows [Version 6.1.7601]
Copyright (c) 2010 Microsoft Corporation. All rights reserved.

C:\Windows\system32>fsutil behavior query disabledeletenotify
DisableDeleteNotify = 0
```

Results explained below:

DisableDelecteNotify = 1 (Windows TRIM commands are disabled)

DisableDelecteNotify = 0 (Windows TRIM commands are enabled)

3. To disable the TRIM function by executing **fsutil behavior set disabledeletenotify 1**

```
Administrator: Command Prompt
Microsoft Windows [Version 6.1.7601]
Copyright (c) 2010 Microsoft Corporation. All rights reserved.

C:\Windows\system32>fsutil behavior query disabledeletenotify
DisableDeleteNotify = 0

C:\Windows\system32>fsutil behavior set disabledeletenotify 1
DisableDeleteNotify = 1
```

Execute **fsutil behavior query disabledeletenotify** again and make sure the TRIM Commands are disabled. ie: DisableDelecteNotify = 1.

Screen rotation:

1. After VGA driver installation completed, type “Customize icons” in search bar.

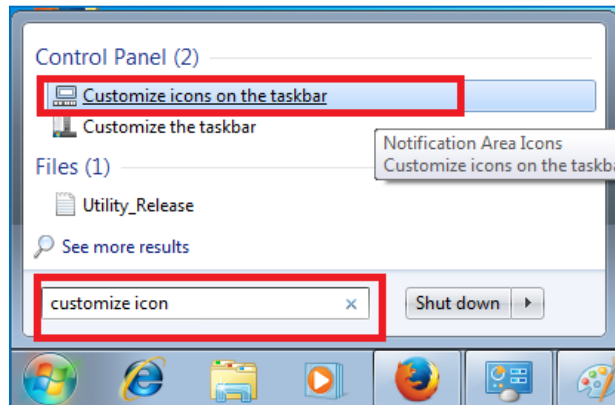

2. Adjust Utility Application to “Show icon and notifications”.

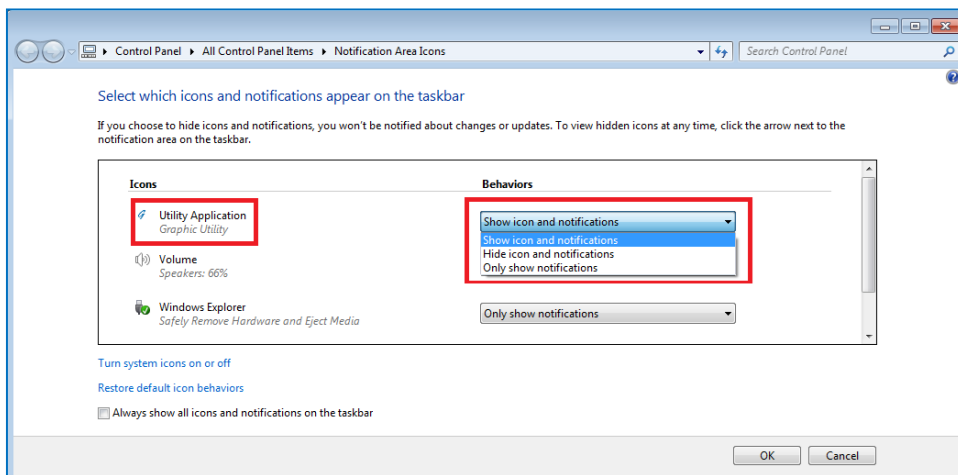

3. A blue icon = Graphic Utility appears on screen, double click it.



4. In Graphic Utility, go to Rotation section. Select the direction of rotation then press Apply to test and OK to save the changes.

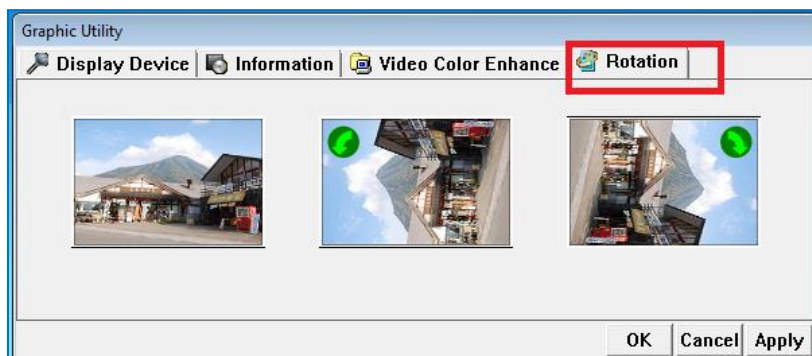

Turn off the display function setting:

For Windows 7 or WES7 OS, click **Start Menu > Control Panel > Power Options**, or simply search for "**Power Options**" (without quotes). You will see a list of different power plans.

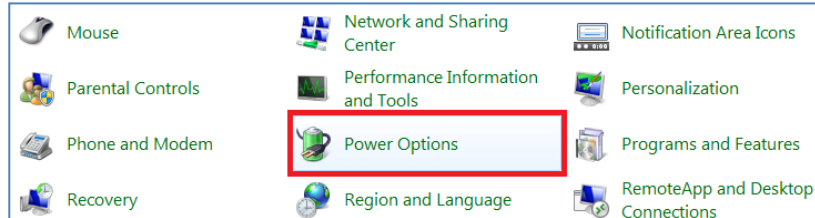

The plan currently in use has a blue dot in front of it. Click "**Change Plan Settings**" next to the power plan currently in use. Click on the drop-down menu list, which is exactly next to "Turn off the display". From the options, you can set the amount of idle time.

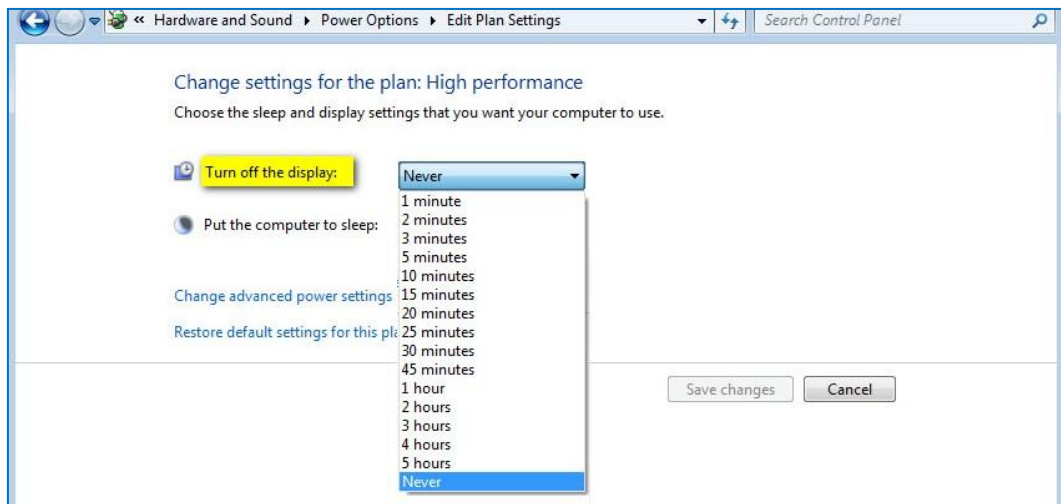

EBOX-336x Series does not support sleep function; it cannot wake up after sleep.

To avoid the unwakeable sleep, please disable function by setting "Put the computer to sleep" to "Never".

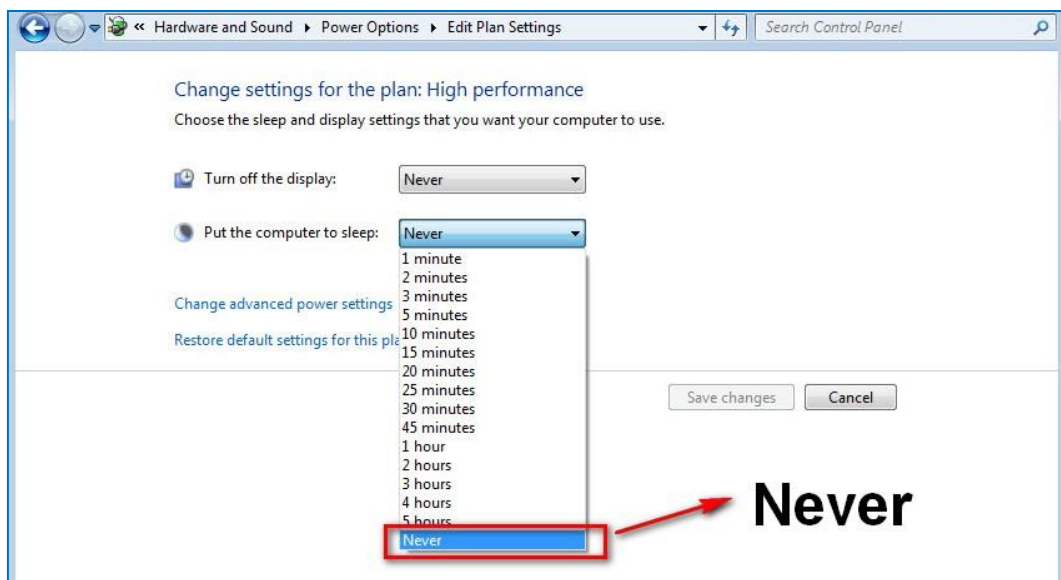

HDMI 1080p video playback:

For windows platform (Windows 7, WES7, XP, XPe):

Click [here](#) to download 1080p video specific use media player DMP_mpc-hc_R7.



DMP_mpc-hc_R7

In media player DMP_mpc-hc_R7 full screen mode, adjust screen with keyboard number pad “8” to increase or “2” to decrease screen height if the screen display is not 100% fitting the monitor.

* DMP_mpc-hc_R7 video player is capable of MPEG-2, AVI, MP4...formats without additional software or codecs installation.

For Linux platform:

Click [here](#) to download EBOX HDMI 1080p video playback Linux Driver & GStreamer Installation Guide.

CANbus information:

In EBOX-336x CANbus Series, serial port (COM4) has been adapted for CANbus use. And the CANbus is onboard, it doesn't need extra external power.

PIN assignment:

J14: COM - 9-pin D-Sub connector (CANbus)

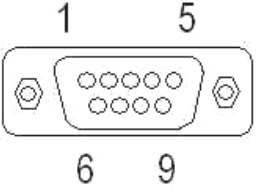
	Pin #	Signal Name	Pin #	Signal Name
	1	--	2	CANL
	3	CAN_GND	4	--
	5	--	6	--
	7	CANH	8	--
	9	--	--	--

EBOX-336x CANbus Series provide a UART (serial) interface with HOST to communicate, support CANbus 2.0A and CANbus 2.0B, to work as a UART to CANbus bridge.

The CANbus only requires a minimum of three pins, those three pins are assigned to Ground,

CANH: CAN High is an input of a "high" voltage.

CANL: CAN Low is an input of a "low" voltage.

In computing terms, the communication architecture is subdivided into 7 layers. Each layer follows a different protocol that is standard. Two standards commonly listed are:

Data frame

CAN network can be configured to work with two different frame formats:

- a. Base frame format CAN 2.0A with 11 bits identifier.
- b. Extended frame format CAN 2.0B with 11-29 bits identifier.

Standards

ISO 11898 specifies physical and datalink layer. Following two commonly listed CAN physical layer and standards:

- a. ISO 11898-2:

This protocol specifies the high-speed at transmission rates of up to 1 Mbit/s.

Supports a cable length of up to 40 meters

- b. ISO 11898-3:

This protocol specifies low-speed at transmission rates above 40 kBit/s up to 125 kBit/s.

Support a much longer cable length, 500 to 1000 meters.

Linux Installation guide For Debian7.0/ Ubuntu10.04

Regarding Debian7.0/ Ubuntu10.04, please follow the steps and suggestions for the system installation on the EBOX-336x Series platform.

The following is a brief instruction; users may configure it according to their specific needs.

1. Basic system installation.

- For Debian7.0, after booting from installation CD, move straight to install system would get a text mode system only, please choose Graphic Install for Graphical Interface OS installation.

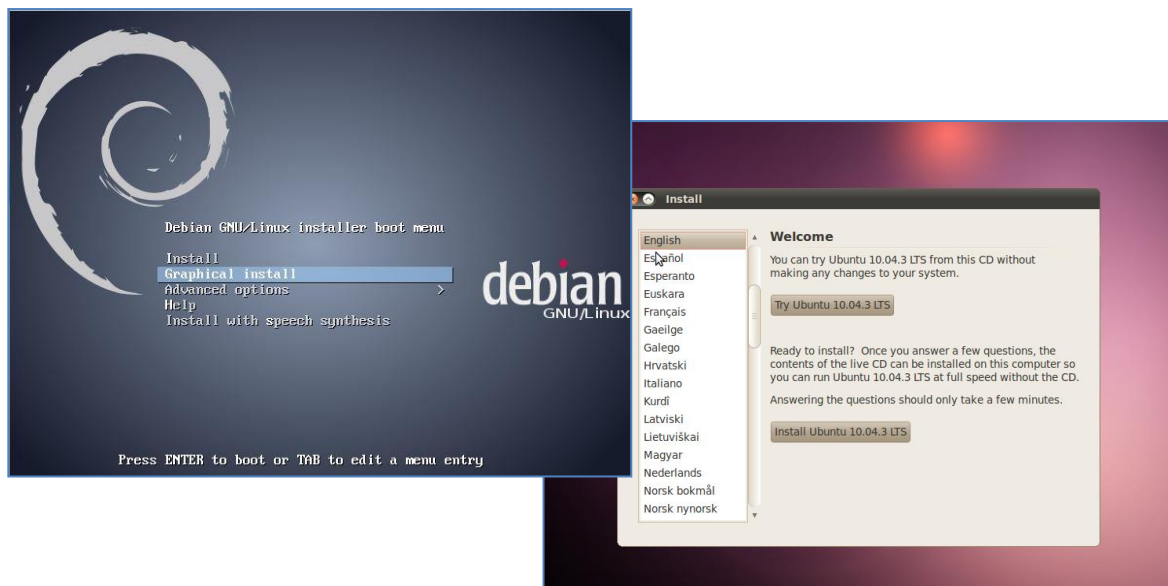

- Set basic configuration such as language, keyboard map and time zone, etc. steps by steps.
- Then the system will detect the network hardware, and requires users to load the firmware files for network device rtl8168, just answer no for this inquiry and move forward.
- Next the system will detect multiple network interfaces on EBOX-336x Series, and users have to decide the primary network interface, both of them could be chosen.

Note: the Ethernet cable must be plugged in during this period.

Configure the network

Please enter the hostname for this system.

The hostname is a single word that identifies your system to the network. If you don't know what your hostname should be, consult your network administrator. If you are setting up your own home network, you can make something up here.

Hostname:

- During installation process, the system would ask users to create partitions for operating system. Following example is using entire disk for the beginner. Choose “Guided - use entire disk”.

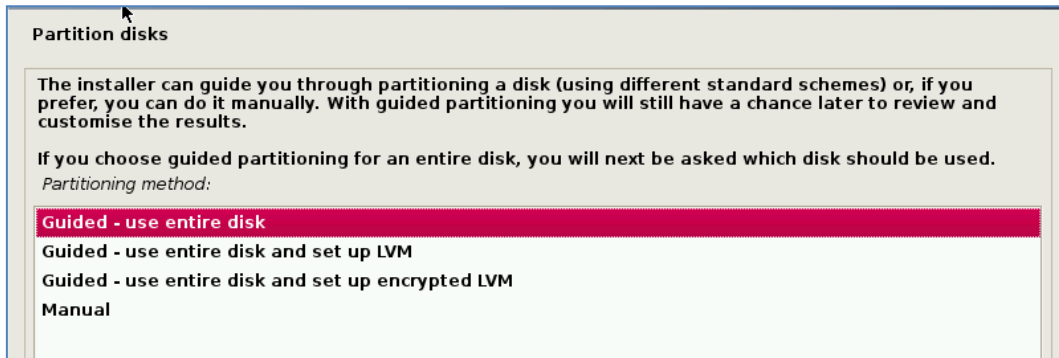

- Select “Yes” to create the partition.

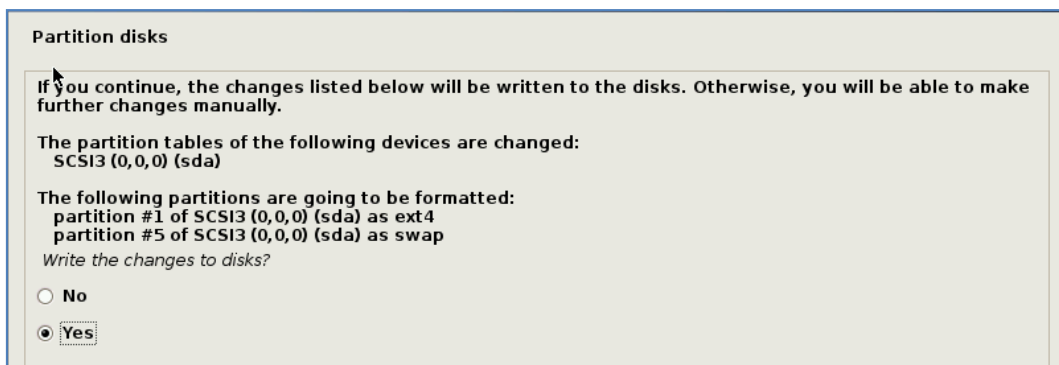

- Then the system would keep popping out questions for configuration, suggestions as below:

For Software selection:

Please check both Debian desktop environment and standard system utilities, then click to continue. It would start the package installation, and around hundred packages would be installed, after installation completed, the next indication message would pop up.

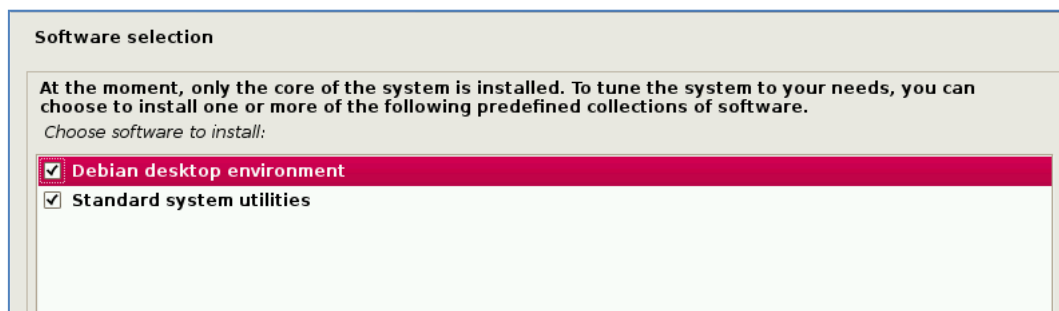

For Install the GRUB boot loader on a hard disk:
Answer YES to complete the installation as last procedure.

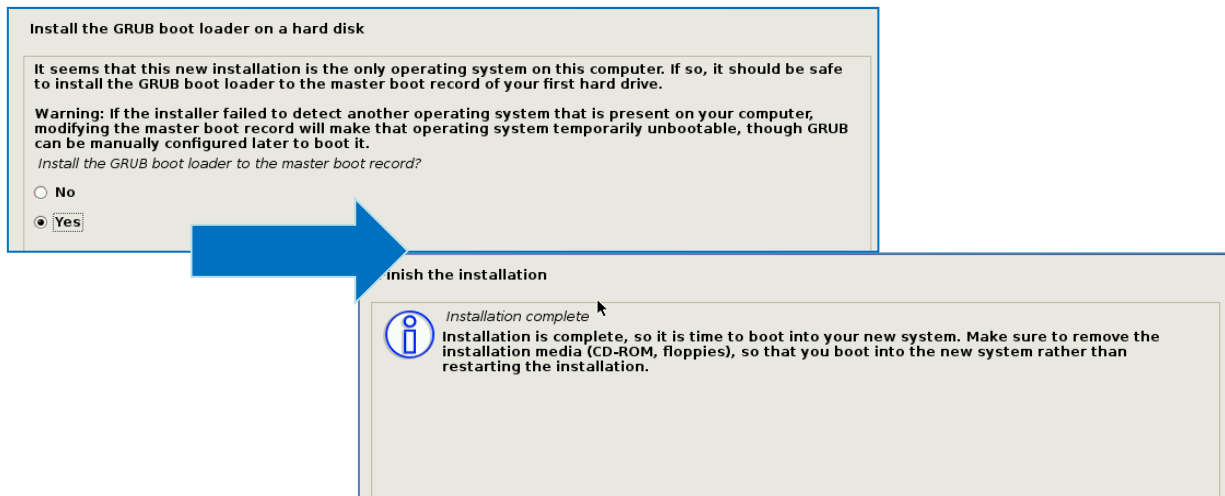

- When it's completed, the disc tray will eject with pop-up message, press continue to restart and be ready to enjoy the new system!



The Debian7.0

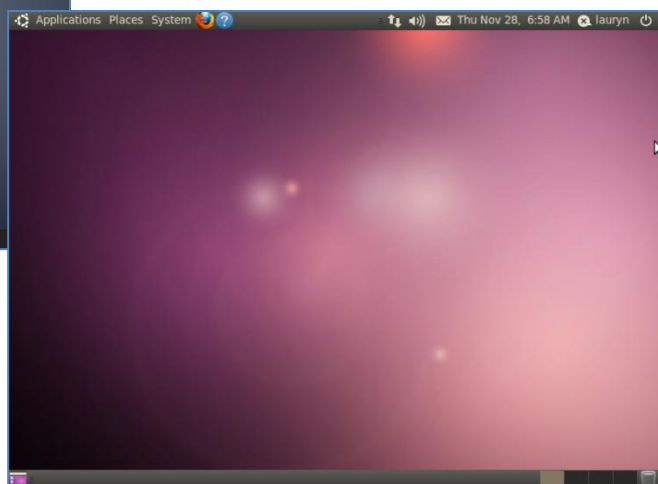

The Ubuntu10.04

2. Install the VGA driver (Console mode)

- Download VGA driver from EBOX website.
- Switch to console mode by pressing key <Ctrl> + <Alt> + <F1>, then copy the VGA driver rdc_drv.so to driver folder /usr/lib/xor/modules/drivers/.
- Follow instruction below to execute.

```
#/etc/init.d/gdm stop
#X -configure
#cp /root/xorg.conf.new /etc/X11/xorg.conf
#/etc/init.d/gdm restart
```

✂ Please click [xorg.conf](#) to download for your system, if the display is out of range.

- Reboot and make sure all the display is normal then set the resolution as requested.

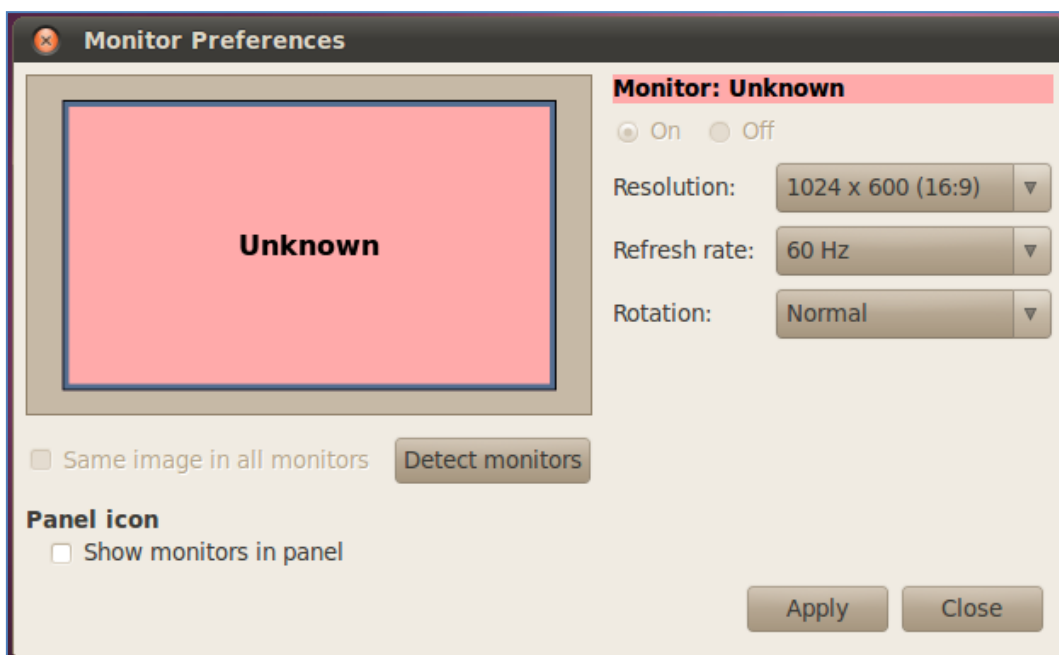

The supported resolutions:

1920x1080 (16:9)	1280x1024 (5:4)	1280x720 (16:9)
1600x1200 (4:3)	1440x900 (16:10)	1024x768 (4:3)
1680x1050 (16:10)	1280x960 (4:3)	800x600 (4:3)
1400x1050 (4:3)	1366x768 (16:9)	640x480 (4:3)
1440x960 (3:2)	1360x768 (16:9)	
1400x960	1280x768 (16:10)	

3. The system configuration:

Enable the Auto login System / Administration / Login Screen

Execute the utility “Login Screen” and enter the password to process it



Set the Log in as “user account” automatically.

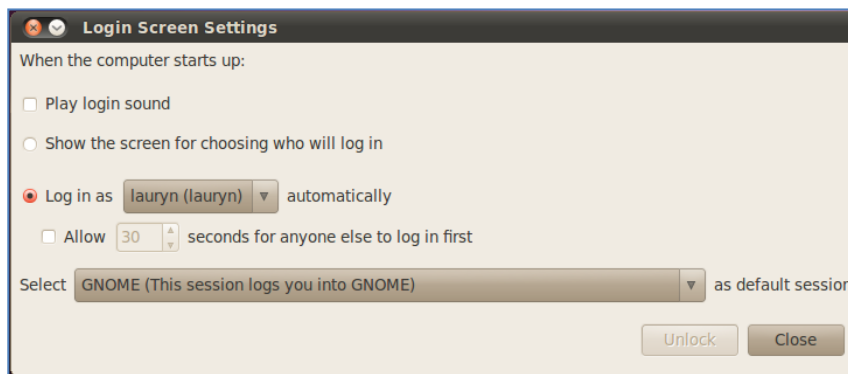

Disable the power saving mode when system idle, System / Preference / Screensaver

Unmarked the option “Active the screensaver when computer is idle”

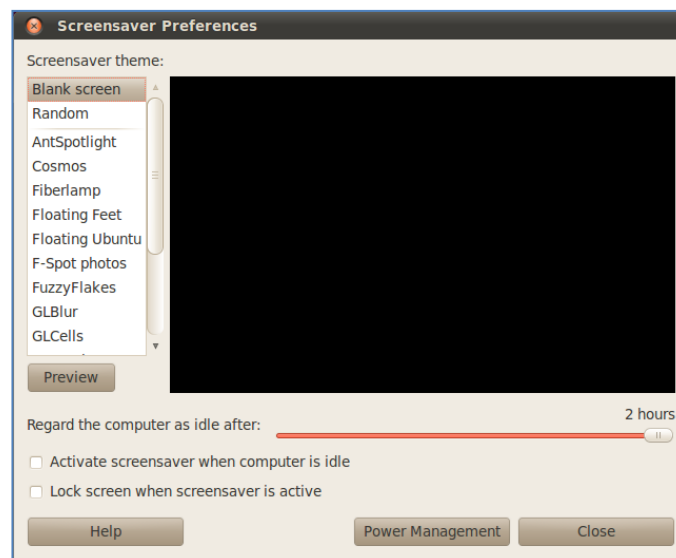

Click close to complete the system configuration.

4. Setting adjustment for Gigabit LAN device (RTL-8111/8168 for Debian and Ubuntu system only).

- To add the parameters “pci=noms” in the line of Linux of GRUB as below. The MSI/MSI-X must be disabled for application of Gigabit LAN (RTL-8111/8168) on the EBOX-336x Series, and it could be set permanent by edition of file /boot/grub/grub.cfg.

```
GNU GRUB  version 1.99-27+deb7u1

setparams 'Debian GNU/Linux, with Linux 3.2.0-4-486'

load_video
insmod gzio
insmod part_msdos
insmod ext2
set root='(hd0,msdos1)'
search --no-floppy --fs-uuid --set=root 16dcc3b2-7d16-4b1e-9f79-bb79\
a94af682
echo 'Loading Linux 3.2.0-4-486 ...'
linux /boot/vmlinuz-3.2.0-4-486 root=UUID=16dcc3b2-7d16-4b1e-9f79-bb\
79a94af682 ro pci=noms
echo 'Loading initial ramdisk ...'
initrd /boot/initrd.img-3.2.0-4-486

Minimum Emacs-like screen editing is supported. TAB lists
completions. Press Ctrl-x or F10 to boot, Ctrl-c or F2 for
a command-line or ESC to discard edits and return to the GRUB
menu.
```

Chapter4

Onboard Connectors Summary

Summary Table for EBOX PCB Board

No.	Description	Type of Connections	Pin nbrs.
J1	SO-DIMM-SOC-200P-1.8V	SO-DIMM socket 200 Pin	200-pin
J3	SATA	SATAIII port connector	7-pin
J5	USB1 (Front)	USB connector	4-pin
J6	USB2 (Front)	USB connector	4-pin
J7	USB3 (Rear)	USB connector	4-pin
J8	USB4 (Inside or Rear)	USB connector	4-pin
J9	Ethernet LAN	RJ-45 connector	8-pin
J10/ J11	Ethernet LAN	G-LAN RJ-45 connector	8-pin
J11/ J12	COM1 port (Rear)	Box Header 5 x 2 2.0mm	9-pin
J12	COM2 port (Rear)	Box Header 5 x 2 2.0mm	9-pin
J13	COM3 port (Front)	Box Header 5 x 2 2.0mm	9-pin
J14	COM4 port (Front)	Box Header 5 x 2 2.0mm	9-pin
J14	Line out	Audio jack	2-pin
J15	DC +8V~+24V Input	DC JACK	1-pin
J15	Mic in	Audio jack	2-pin
J16	Power switch	Power switch	4-pin
J17	DC +8~+24V Input	DC JACK	1-pin
J18	VGA	D-Sub connector	15-pin
J20	Line out	Audio jack	2-pin
J26	mPCIe	mPCIe connector	52-pin
CF1 (CF Card Series)	CF Card	CF Card slot	50-pin
J20 (Printer port Series)	Printer port	Parallel port	25-pin
J25	SIM card holder	SIM card holder	6-pin
J28	HDMI	HDMI connector	19-pin

Note:

[J11](#), [J12](#), [J14](#), [J15](#), [J17](#) and [Rear](#) are specific for EB-336x-L3U4C1 unit only.

Pin Assignments

J3: SATAIII connector

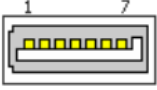
	Pin #	Signal Name	Pin #	Signal Name
	1	GND	2	Transmit+
	3	Transmit-	4	GND
	5	Receive-	6	Receive+
	7	GND		

J5, J6, J8: USB 2.0 (180°)

Horizontal Type	Pin #	Signal Name
	1	VCC
	2	Data --
	3	Data +
	4	GND

J7: USB 2.0 (90°)

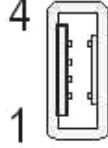
Vertical Type	Pin #	Signal Name
	1	VCC
	2	Data --
	3	Data +
	4	GND

J9, J10, J11: LAN RJ-45 connector

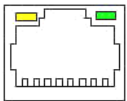
	Pin #	Signal Name	Pin #	Signal Name
	1	FTXD+	2	FTXD-
	3	FRXIN+	4	NC
	5	NC	6	FRXIN-
	7	NC	8	NC

J16: Power switch

	Pin #	Status
	I	ON
	O	OFF

J15, J17: DC-IN 2-pin Jack

	Pin #	Signal Name
	1	+8V~+24V Input
	2	GND

J25: LAN: RJ-45 connector

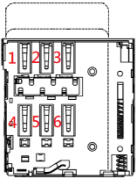
	Pin #	Signal Name	Pin #	Signal Name
	1	SIM-VCC	4	GND
	2	SIM-RST	5	SIM-VPP
	3	SIM-CLK	6	SIM-IO

J18: VGA 15-pin D-Sub connector

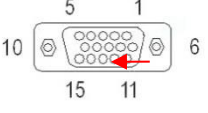
	Pin #	Signal Name	Pin #	Signal Name	Pin #	Signal Name
	1	MR	6	GND	11	NC
	2	MG	7	GND	12	VCC
	3	MB	8	GND	13	HYSYNC
	4	NC	9	NC	14	VSYNC
5	GND	10	GND	15	VCC	

J28: HDMI

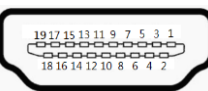
	Pin #	Signal Name	Pin #	Signal Name
	1	TMDS_Data2+	11	TMDS_CLK Shield
	2	TMDS_Data2_Shield	12	TMDS_CLK-
	3	TMDS_Data2-	13	CEC
	4	TMDS_Data1+	14	Reserved
	5	TMDS_Data1_Shield	15	SCL
	6	TMDS_Data1-	16	SDA
	7	TMDS_Data0+	17	DDC/CEC_GND
	8	TMDS_Data0_Shield	18	+5V Power
	9	TMDS_Data0-	19	Hot Plug Detect
10	TMDS_CLK+			

J11 (COM1), J12 (COM2): RS-232/ RS-485/ RS-422, 9-pin D-Sub connector

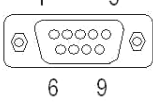
	Pin #	Signal Name	Pin #	Signal Name
	1	DCD/ RS-485- / 422TX-	2	RXD/ RS-485+ / 422TX+
	3	TXD/ 422RX+	4	DTR1/ 422RX-
	5	GND	6	DSR
	7	RTS	8	CTS
9	RI	--	--	

J13 (COM3), J14 (COM4): RS-232, 9-pin D-Sub connector

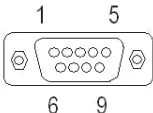
	Pin #	Signal Name	Pin #	Signal Name
	1	DCD	2	RXD
	3	TXD	4	DTR
	5	GND	6	DSR
	7	RTS	8	CTS
9	RI	--	--	

For CANbus version:

J11 (COM1), J12 (COM2): RS-232/ RS-485/ RS-422, 9-pin D-Sub connector

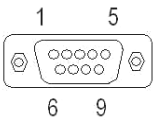
	Pin #	Signal Name	Pin #	Signal Name
	1	DCD/ RS-485- / 422TX-	2	RXD/ RS-485+ / 422TX+
	3	TXD/ 422RX+	4	DTR1/ 422RX-
	5	GND	6	DSR
	7	RTS	8	CTS
	9	RI	--	--

J11 (COM1), J12 (COM2): GPIO P4 and P5, 9-pin D-Sub connector

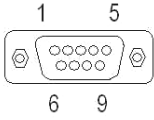
	Pin #	Signal Name	Pin #	Signal Name
	1	PORT 40/ PORT 50	2	PORT 44/ PORT 54
	3	PORT 41/ PORT 51	4	PORT 45/ PORT 55
	5	GND	6	PORT 46/ PORT 56
	7	PORT 42/ PORT 52	8	PORT 47/ PORT 57
	9	PORT 43/ PORT 53	--	--

J13 (COM3): RS-232, 9pin D-Sub connector

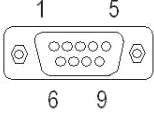
	Pin #	Signal Name	Pin #	Signal Name
	1	DCD	2	RXD
	3	TXD	4	DTR
	5	GND	6	DSR
	7	RTS	8	CTS
	9	RI	--	--

J14 (COM4): CANbus, 9pin D-sub connector

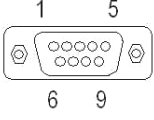
	Pin #	Signal Name	Pin #	Signal Name
	1	--	2	CANL
	3	CAN_GND	4	--
	5	--	6	--
	7	CANH	8	--
	9	--	--	--

For 8-bit GPIO version with RS-232 port:**J11 (COM1): GPIO P4, 9-pin D-sub connector**

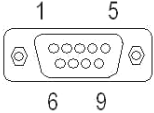
	Pin #	Signal Name	Pin #	Signal Name
	1	PORT 40	2	PORT 44
	3	PORT 41	4	PORT 45
	5	GND	6	PORT 46
	7	PORT 42	8	PORT 47
	9	PORT 43	--	--

J12 (COM2): GPIO P5, 9-pin D-Sub connector

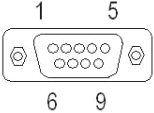
	Pin #	Signal Name	Pin #	Signal Name
	1	PORT 50	2	PORT 54
	3	PORT 51	4	PORT 55
	5	GND	6	PORT 56
	7	PORT 52	8	PORT 57
	9	PORT 53	--	--

J13 (COM3), J14 (COM4): RS-232, 9-pin D-Sub connector

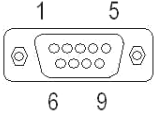
	Pin #	Signal Name	Pin #	Signal Name
	1	DCD	2	RXD
	3	TXD	4	DTR
	5	GND	6	DSR
	7	RTS	8	CTS
	9	RI	--	--

For 8-bit GPIO version with RS-485 port:

J11 (COM1), J12 (COM2): RS-485, 9-pin D-Sub connector

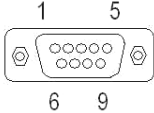
	Pin #	Signal Name	Pin #	Signal Name
	1	RS-485-	2	RS-485+
	3	TXD	4	DTR1
	5	GND	6	DSR
	7	RTS	8	CTS
	9	RI	--	--

J13 (COM3): GPIO P0, 9-pin D-Sub connector

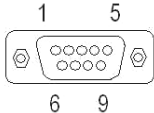
	Pin #	Signal Name	Pin #	Signal Name
	1	PORT 00	2	PORT 04
	3	PORT 01	4	PORT 05
	5	GND	6	PORT 06
	7	PORT 02	8	PORT 07
	9	PORT 03	--	--

J14 (COM4): GPIO P1, 9-pin D-Sub connector

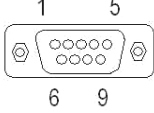
	Pin #	Signal Name	Pin #	Signal Name
	1	PORT 10	2	PORT 14
	3	PORT 11	4	PORT 15
	5	GND	6	PORT 16
	7	PORT 12	8	PORT 17
	9	PORT 13	--	--

For RS-485 x3, x4 version:**J11 (COM1): RS-232, GPIO P4, 9-pin D-sub connector**

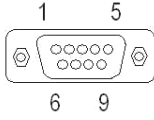
	Pin #	Signal Name	Pin #	Signal Name
	1	DCD/ PORT 40	2	RXD/ PORT 44
	3	TXD/ PORT 41	4	DTR/ PORT 45
	5	GND	6	DSR/ PORT 46
	7	RTS/ PORT 42	8	CTS/ PORT 47
	9	RI/ PORT 43	--	--

J12 (COM2): RS-232, GPIO P5, 9-pin D-Sub connector

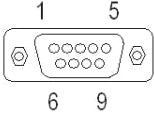
	Pin #	Signal Name	Pin #	Signal Name
	1	DCD/ PORT 50	2	RXD/ PORT 54
	3	TXD/ PORT 51	4	DTR/ PORT 55
	5	GND	6	DSR/ PORT 56
	7	RTS/ PORT 52	8	CTS/ PORT 57
	9	RI/ PORT 53	--	--

J13 (COM3): RS-232, RS-485, GPIO P0, 9-pin D-Sub connector

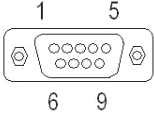
	Pin #	Signal Name	Pin #	Signal Name
	1	DCD/ RS-485-/ PORT 00	2	RXD/ RS-485+/ PORT 04
	3	TXD/ PORT 01	4	DTR/ PORT 05
	5	GND	6	DSR/ PORT 06
	7	RTS/ PORT 02	8	CTS/ PORT 07
	9	RI/ PORT 03	--	--

J14 (COM4): RS-232, RS-485, GPIO P1, 9-pin D-Sub connector

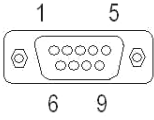
	Pin #	Signal Name	Pin #	Signal Name
	1	DCD/ RS-485-/ PORT 10	2	RXD/ RS-485+/ PORT 14
	3	TXD/ PORT 11	4	DTR/ PORT 15
	5	GND	6	DSR/ PORT 16
	7	RTS/ PORT 12	8	CTS/ PORT 17
	9	RI/ PORT 13	--	--



*Chapter***5**

Taking Care of EBOX

This section provide guidelines on using EBOX-336x Series – Safe using, Storing and Handling.

Storing

- ▶ Do not place EBOX in a location that is subject to:
 - Heating sources, such as stove, oven, heater, radiator or air duct
 - Direct contact from sunlight
 - Rain or moisture area
 - Excessive dust accumulation area
 - High humidity place
 - Constant or occasional mechanical movement, vibration or shock
 - Strong magnets or magnetic fields or magnetically unshielded speakers
 - Out of the operating temperature
- ▶ Do not place other electronic device or electrical equipment near EBOX. The electromagnetic field of EBOX may cause interference subjecting to malfunction.
- ▶ Provide adequate air ventilation (circulation) to prevent internal buildup of heat. Do not place EBOX near behind the curtains or draperies, in between two books that block its ventilation slots. Leave a space of at least 8 inches (20cm) behind the sides and back panel of the EBOX.
- ▶ Change of environmental temperature: Problems may occur when there is a sudden change of environmental temperature, or if the EBOX is brought directly from a cold location to a warm one, moisture may condense inside EBOX. Turn off the device, and contact your nearest dealer.
- ▶ Check the surrounding appliance(s) before using EBOX. Since the EBOX uses high-frequency radio signal and may interfere with radio or TV reception causing interference or poor signal display. When happens, relocate the EBOX by a suitable distance away from it.
- ▶ Do not drop EBOX from working table nor place heavy objects on top of it.

Cleaning EBOX

- ▶ Clean EBOX with a soft, dry cloth or a soft cloth lightly moistened with a mild detergent solution.
- ▶ Do not use any type of abrasive pad, scouring powder, or solvent such as alcohol or benzene, as these may damage the finish of EBOX.
- ▶ When a solid object falls or a liquid spills onto EBOX, turn off EBOX immediately; unplug the LAN and power cables. Contact a qualified person or your dealer to check the EBOX before you use it again.
- ▶ Always disconnect the power cord from the power source before cleaning EBOX.

Troubleshooting

This section describes the techniques of resolving some basic problems that you encounter when using EBOX. For more troubleshooting guidelines, please contact your nearest dealer for technical support.

Troubleshooting EBOX

A. EBOX does not start –

- ▶ Make sure EBOX is properly secured and plugged into a power source before it is turned on.
- ▶ Make sure the power indicator shows the power is on.
- ▶ When EBOX unit is plugged into a power strip or the UPS (Uninterruptible Power Supply), make sure the power strip or UPS is turned on and working normally.
- ▶ Check if your display monitor is properly plugged into a power source and turned on. Make sure the brightness and contrast controls are adjusted correctly. See the manual that came with display (monitor) for details.
- ▶ Check if power control button function well by removing the AC adaptor. Wait for one minute, and then reattach all power connection before pressing the power button.
- ▶ Condensation may cause EBOX malfunction for a while. If happens, do not use EBOX for at least one hour.
- ▶ When all above guidelines checked and EBOX unit still not work. Remove the power adaptor from EBOX, unplug the power supply, and plug it in again. Then turn on the power.

B. BIOS Error Message –

BIOS error message appears when EBOX starts

If BIOS error message appears, press any key to resume or, press to enter BIOS setup main menu, follow these steps:

1. Press or <Esc>, and the BIOS Setup main menu appears, check if storage is detected. If it is not detected, use Direction keys <↑↓> to choose “AUTO” and then go back to the main menu by pressing <Esc>. Move your cursor down with Direction keys <↓>, and press F4 to “Save and Exit”,
2. Go to “Save & Exit” menu using the Direction keys <↑↓> and choose the option “Restore Defaults”, then press <Enter>. A message dialog appears as seen below, hit “Y” key and presses <Enter> to save and recover to the factory setting.

“Restore Defaults (Y/N)? Y”

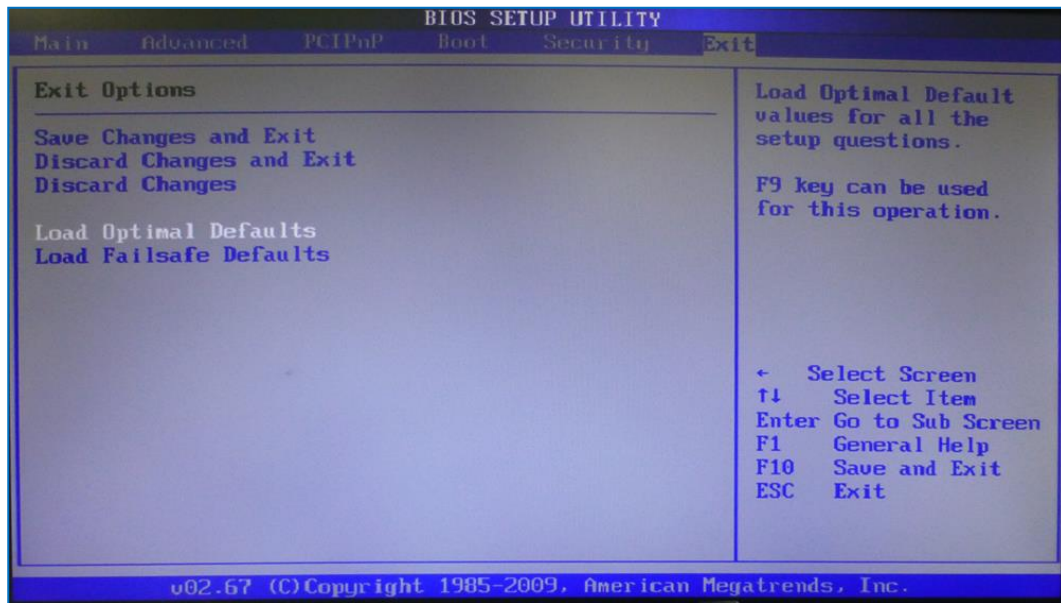

(BIOS Setup menu "Save & Exit")

C. "Operating System Not Found" –

A message indicating "Operating system not found" appear when unit starts (Windows won't start)

- ▶ Enter BIOS setup main menu by pressing key, be sure that the C: drive is enable.
- ▶ If Windows still does not start, follow these steps to initialize the BIOS:
 1. Turn off EBOX unit.
 2. Remove any peripheral devices connected to EBOX unit.
 3. Restart EBOX unit.
 4. Press or <Esc> to enter BIOS Setup main menu window.
 5. Follow the steps as written in item **B. BIOS error message.**
- ▶ If EBOX unit connected to a CD/ DVD or USB Drivers, remove all peripherals. And restart to check if Windows operating system starts properly. If EBOX unit continues to display the message "Operating system not found," and Windows does not start, please contact nearest dealer for servicing.

Chapter 6

Terms and Conditions

Warranty

The warranty terms for EBOX are twelve (12) months from the shipped month. During the warranty period, DMP Electronics will repair replace the product covered under this limited warranty.

Service and Support

DMP Electronics Inc. provides the technical support for hardware problems with your system throughout the warranty period. The technical support service is limited to configuration and operation of EBOX sold by DMP Electronics Inc. The technical support service does not offer software tutoring or training.

Return Merchandise Authorization (RMA) policy

If the DMP staff or dealer determines that a part is defective. Purchaser must call our technical support service to obtain an RMA number before attempting to return any part. Please refer to your nearest dealer for:

To obtain an RMA number, Purchaser must follow procedures as below :

1. Complete the DMP Electronics Inc. standard RMA Form and fax back to the RMA Department.
2. The RMA Number must be used within 7 DAYS.
3. The RMA Number must be shown clearly on your shipping label.
4. DMP Electronics Inc. must receive all Returns before a replacement will be sent.
5. Repair cost depends on the parts, damage reasons, and whether under warranty period...etc. The Seller will charge the Purchaser in a reasonable price.
6. A copy of the invoice for the RMA product(s) will also be shipped to Purchaser.
7. The freight of return to DMP Electronics Inc. is charged to the Purchaser's account and accompanied by an RMA number. Any Returns with freight collect will be refused and returned to you. After Repairing, the cost of freight will be paid by Seller.
8. DMP Electronics Inc. must receive all returned goods within the warranty period.

Shipping Policy

The Purchaser must pre-pay shipping for any defective system or parts returned under the warranty. DMP Electronics Inc. shall not be liable for risk of loss or damage during shipment of the returned system or parts if you fail to insure the shipment. All products must be shipped back to DMP Electronics Inc. in original or equivalent packaging. DMP Electronics Inc. will ship the repaired or replacement product(s) to the Purchaser by freight prepaid. Purchaser assumes the risk of loss. DMP Electronics Inc. shall not be responsible for failure of the delivery service to make on-time delivery.